



## **Δ STOPPER POSITION MEASURING SYSTEM - SPM** **WHEN INCREASED REQUIREMENTS** **MUST BE ENSURED**



Meets all relevant normative requirements  
(GMP, FDA, ISO, ASTM etc.) and offers a  
CFR 21 Part 11 compliant IT System

 **innotec AG**

# STOPPER POSITION MEASURING SYSTEM - SPM CFR 21 PART 11 COMPLIANT IT SYSTEM

The mobile Stopper Position Measuring System of 3D innotec AG is used for the automated monitoring of the stopper movement in pre-filled syringes and cartridges during transport at elevated altitudes using simulated pressure cycles.

The method for measuring syringe stopper movement mimics the typical pressure build-up of a cargo jet for air cargo shipments and is implemented using the standard ASTM D6653/D6653M test methods.

Example of a test sequence with 2 cycles :

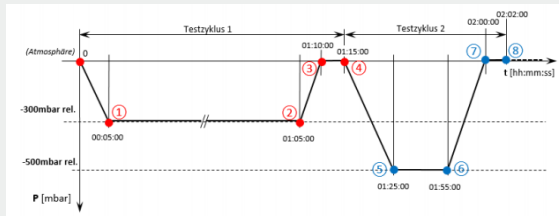

Up to 100 recipes with a maximum of 5 test cycles with 4 test steps each can be created by an authorized operator.

The transport of prefilled syringes and cartridges can cause an expansion and contraction of the air bubble inside the syringe or cartridge due to the pressure difference at differing altitudes. This can cause the syringe stopper to rise into non-sterile areas, possibly drawing silicone and other contaminants into the product.

To counter this potential risk to the sterility of the product, a system for recording the movement of the syringe stopper was

developed.

Representation of pressure cycles:

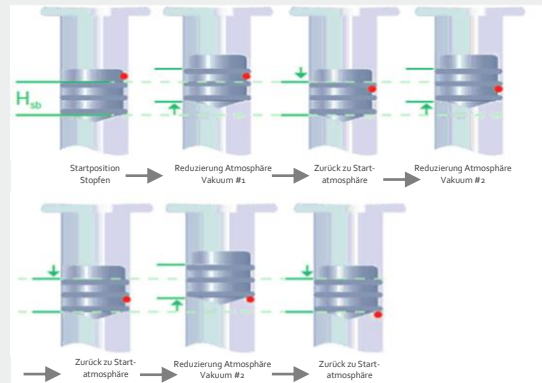

Advances in Prefilled Syringe Technology, IPT 24 2007, S. 74

A low-pressure of up to -800 mbar can be simulated over several pressure cycles of up to 9 hours duration. The measurement of the stopper position is carried out via images from the integrated and calibrated camera. Using holders developed specifically for the product, up to 10 prefilled syringes can be measured simultaneously.

Result of a measurement with 10 syringes:

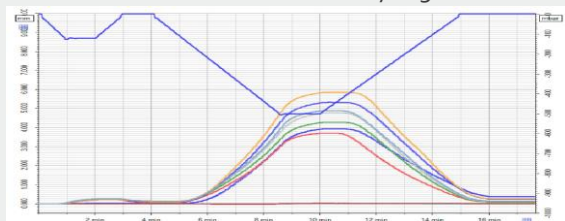

The movement recording of the 10 different stoppers and in blue the pressure curve that was used.

# STOPPER POSITION MEASURING SYSTEM - SPM

## FACTS AND ADVANTAGES

After the simulation has run, the system automatically creates a test report. The pressure cycles and measuring times can be set and are stored in the device. This ensures that the same parameters can be used. Measurements are therefore reproducible and documented by the test protocol.

The location-independent system can be seamlessly integrated into existing IT systems. The system is designed to comply with the pharmaceutically relevant aspects, such as strict adherence to current GMP standards, the use of FDA-compliant building materials and the conformity of the IT system in accordance with CFR 21 Part 11.

On request, the system can be qualified by 3D innotec AG. The customer receives a complete documentation, which includes operating instructions and a system description as well as DQ, IQ, OQ, FAT and SAT.

### Advantages

- Mobile unit
- Low maintenance operation
- System availability 7 x 24 h
- User administration and control of rights
- Holders are developed and manufactured according to customer and requirement specifications
- High process reliability and monitoring
- CFR 21 Part 11 compliant IT system
- PM Control, PM Quality and Audit Trail integrated
- Meets all relevant normative requirements
- Customer-specific adaptations possible at any time
- Requires no other media connections apart from the mains power supply

### Facts

- Recording speed: 1 to 60 images/min
- Accuracy of the position determination of the stopper: > 0.1 mm
- Accuracy of the pressure recording:  $\pm 2\%$ .
- Measuring time: Up to 9 h
- Measuring temperature:  $23 \pm 2^\circ\text{C}$
- Compliant with GMP
- 21 CFR Part 11 compliant

# STOPPER POSITION MEASURING SYSTEM - SPM

## TECHNICAL DATA AND SPECIFICATIONS

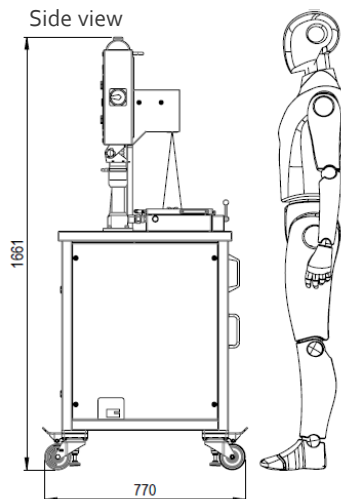
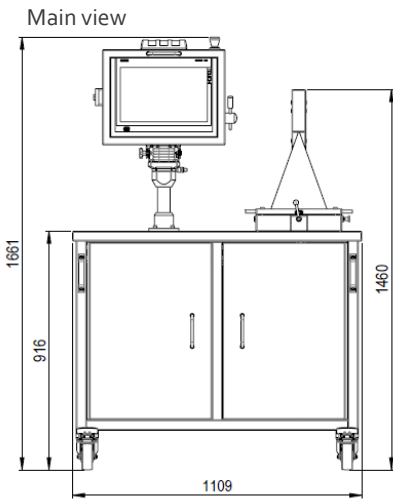

### Technical Data

Dimensions (lxwxh)	1109 x 789 x 1646 mm
Weight	approx. 250 kg (empty weight)
Height of work surface	916 mm
Machine frame	Aluminium
Vacuum chamber, Panelling	Stainless steel 1.4301 (elektropoliert)
Vacuum chamber inside (lxbxh)	300 x 222 x 40 mm
Vacuum chamber temperature	23°C ±2K (no active temp. control)
Vacuum chamber pressure	0 bar...-0.8 bar atm. (0,2bar abs.) ± 0,005 bar (control deviation)
Max. time to pressure stability	-40mbar (-4kPa rel.) in 20s / -500mbar (-50kPa rel.) in 300s
Recording interval	Parameterizable (0,1...1 Measur./s)
Camera system	KEYENCE – S/W camera with 16x speed and 21 Mpx
Measuring accuracy camera	±0,1mm min.
Backlight	KEYENCE – white LED
Industrial PC (Computer)	SIMATIC IPC477E; 16GB DDR4; 4xUSB; Ethernet; Win7/10; IP65
Operating panel	15 Zoll TFT Touch 1280 x 800, incl. touch pen, rotatable and tiltable, indicator light with alarm buzzer
Power supply	230V~ / 0,1kVA (L/NL/PE); Power cable (L=5m) Type SEV1011/T12



Live image from Keyence camera

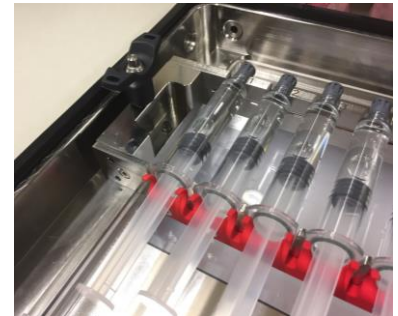

Syringe holder in vacuum chamber

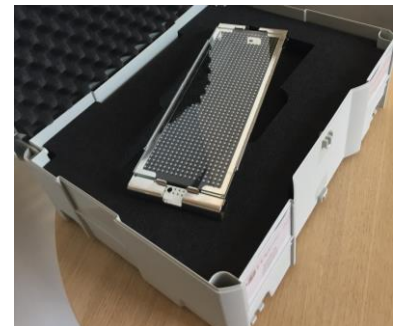



Calibration plate





KEYENCE – S/W camera with 21 Mpx

3D innotec AG  
Hofstetstrasse 8  
9300 Wittenbach

 +41 (0) 71 571 96 70

 +41 (0) 71 571 96 79

 [info@3dinnotec.ch](mailto:info@3dinnotec.ch)

 [www.3dinnotec.ch](http://www.3dinnotec.ch)